

MODEL F-1000 SPECIFICATIONS



**WATERFREE URINAL
VITREOUS CHINA**



SEALED CARTRIDGE

DESCRIPTION

The Falcon model F-1000 is a vitreous china wall hung, wall outlet waterfree urinal. It requires no flush valve or water supply, and plumbs to standard drain connections. The F-1000 utilizes a replaceable sealed locking cartridge, with bayonet tabs, is made of recyclable ABS plastic and utilizes a 100% biodegradable liquid sealant.

F-1000 INCLUDES

- Vitreous china fixture
- Housing (H-1, Mod. 3)
- Cartridge kit*
- One piece wall bracket with anchors
- Uni-coupler
- Drain line test cap
- Instruction sheet
- Professional cartridge change key

*Additional cartridges sold separately

COLORS

Standard white; available in other colors

NOMINAL DIMENSIONS (W x H x D)

19.25 x 26.25 x 14.375 inches [488 x 666 x 366 mm]

APPROXIMATE WEIGHT

54 lbs. [24.5 kg]

COMPLIANCE CERTIFICATIONS

Meets ANSI/ASME A112.19.19-2006 for vitreous china non-water urinals. Meets the American Disabilities Act guidelines and ANSI A117.1 for accessible and usable buildings and facilities. Complies with International Plumbing Code and National Standard Plumbing Code.



HOUSING

The factory installed housing is comprised of a bowl with a tailpiece and a mounting flange of 316 Stainless Steel. It is sealed into the bowl drain opening by a profile gasket made of a synthetic rubber. The housing and gasket are compressed into the drain opening by the installation of a retaining nut, and a friction washer.

CARTRIDGE KIT

The patented cartridge is engineered to last an average of three to four months in typical installations and to receive urine through drain holes. Urine passes through an immiscible layer of biodegradable sealant, continues through a siphon trap system, and flows out through a baffle to prevent the loss of sealant. A discharge tube in the housing directs the flow of urine into the building drain system. The cartridge is designed as a replaceable component when its function has been exhausted.

DRAIN COUPLER

The housing is connected to the building drain system by means of the Falcon Uni-coupler. The coupler conforms to NSF 14 for plastic pipes and fittings. It is designed to be used in both retrofit and new installations. It offers a variety of configurations which allow it to couple to most existing drain openings.

DRAIN CONNECTION AND MATERIAL

Installs on standard 2-inch drain connections with spud flange or threaded nipple. Suitable DWV materials include cast iron, galvanized steel, ABS, and PVC. Waterfree urinals are not recommended for installation on copper DWV due to copper's susceptibility to corrosion.

The information in this document is subject to change without notice.

MODEL F-1000 SPECIFICATIONS

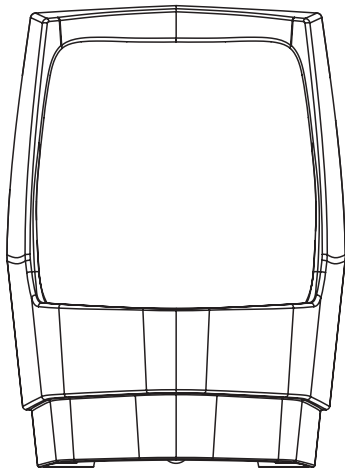

FRONT VIEW

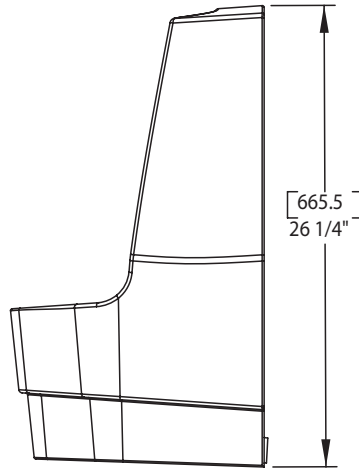

[665.5]
26 1/4"

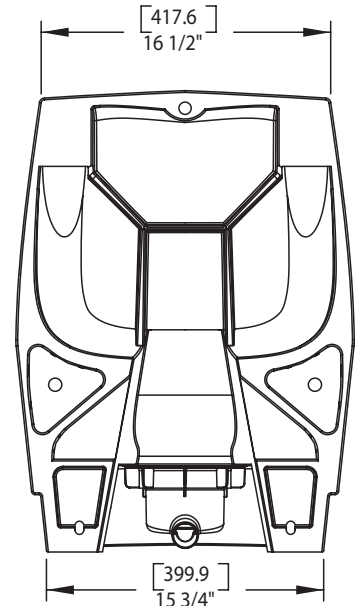

BACK VIEW

[417.6]
16 1/2"

[399.9]
15 3/4"

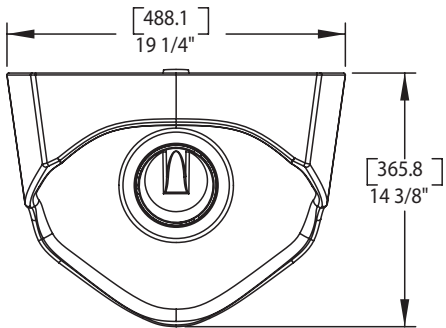

TOP VIEW

[488.1]
19 1/4"

[365.8]
14 3/8"

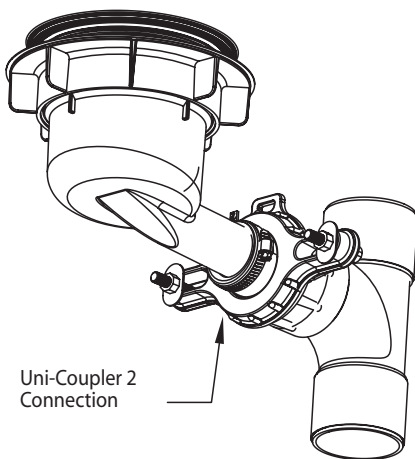

Uni-Coupler 2
Connection

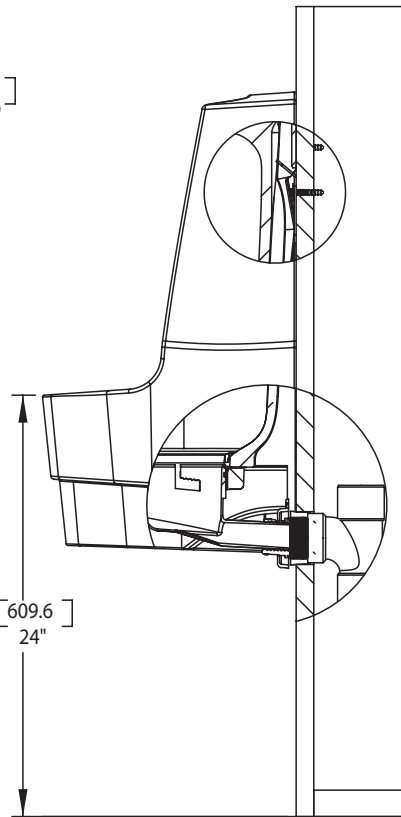

[609.6]
24"

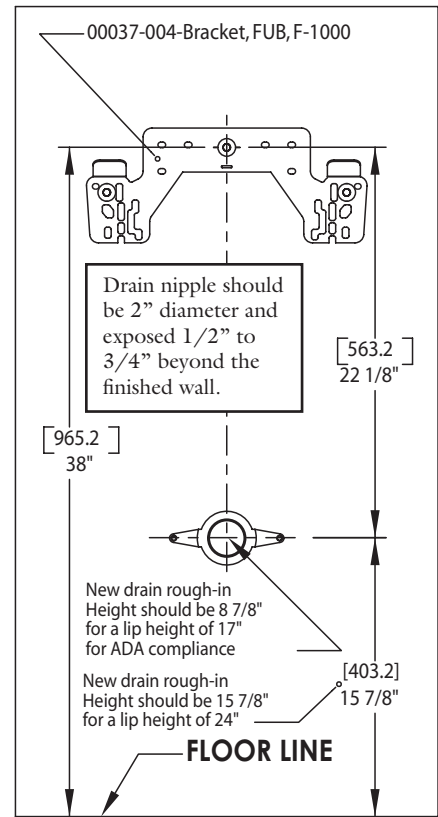

Rev. 5/26/2006

The information in this document is subject to change without notice.



Falcon Waterfree Technologies, LLC
Tel: 866.275.3718 (toll-free) • Fax: 616.954.3579 • info@falconwaterfree.com

www.falconwaterfree.com



F-1000 FIXED UNI-BRACKET CARRIER STUD PLACEMENT

Note: Fractional dimensions are rounded to the nearest 1/16"
Dimensions in (mm) are rounded to the nearest 1mm

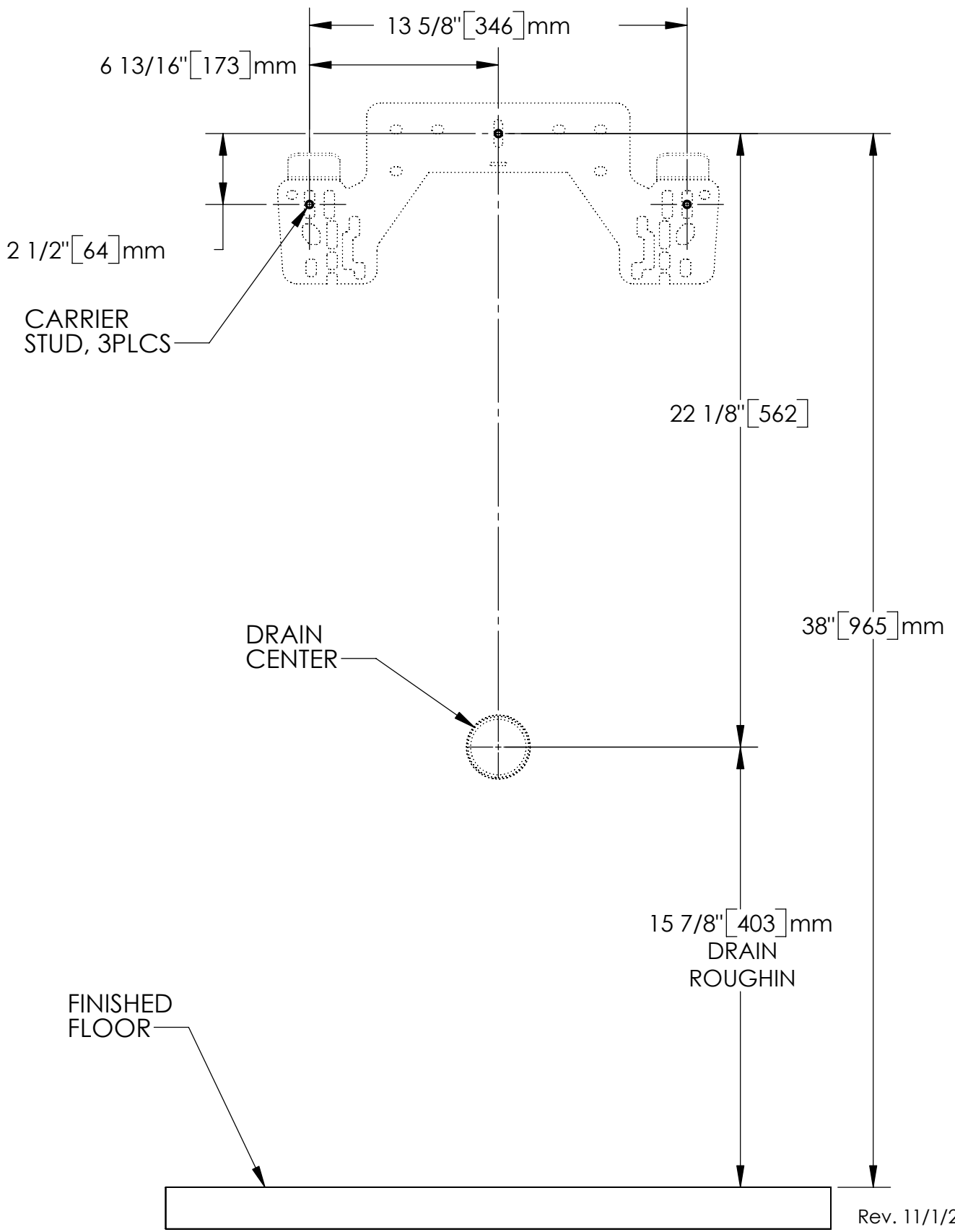

Rev. 11/1/2006



F-1000 ADA FIXED UNI-BRACKET CARRIER STUD PLACEMENT

Note: Fractional dimensions are rounded to the nearest 1/16"
Dimensions in (mm) are rounded to the nearest 1mm

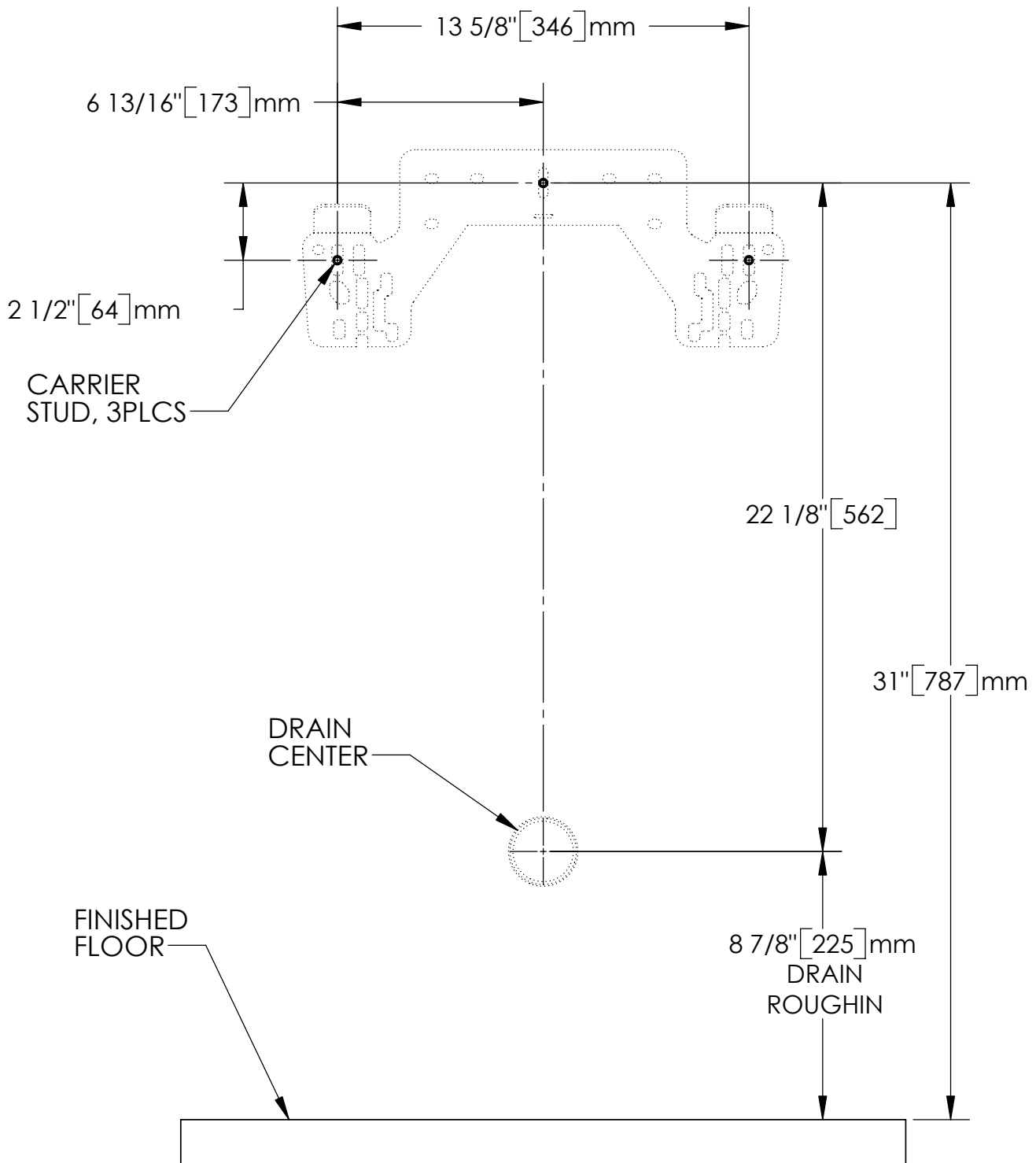

Rev. 11/1/2006