



F1000 PRODUCT SPECIFICATION

The Falcon model F1000 is a vitreous china wall hung, wall outlet waterless urinal. It requires no flush valve or water supply, and plumbs to standard drain connections. The F1000 utilizes a replaceable sealed cartridge with bayonet locking features with O-rings. The cartridge is made of recyclable ABS plastic and utilizes a 100% biodegradable liquid sealant.

F1000 INCLUDES

Vitreous china fixture	Uni-coupler*
Installed housing (H-1, Mod. 3)	Drain line test cap*
Cartridge kit*	Installation instruction sheet
One-piece wall bracket with anchors*	Professional cartridge change key

Additional cartridges sold separately

COLORS

Standard white

NOMINAL DIMENSIONS (W x H x D)

19.375 x 25.875 x 14.375 inches (492 x 657 x 366 mm)

APPROXIMATE WEIGHT

63 lbs. (28.6 Kg)

COMPLIANCE CERTIFICATIONS

Meets ANSI/ASME A112.19.19-2006 for vitreous china non-water urinals. Meets ADA guidelines and ANSI A117.1 for accessible and usable buildings and facilities. Complies with International Plumbing Code and National Standard Plumbing Code standards.

HOUSING

The factory installed housing is comprised of a bowl with a tailpiece and a mounting flange of 316 Stainless Steel. It is sealed into the bowl drain opening by a profile gasket made of a synthetic rubber. The housing and gasket are compressed into the drain opening by the installation of a retaining nut and a friction washer.

*AVAILABILITY VARIES BY REGION

CARTRIDGE KIT*

The patented cartridge is engineered to last about 7,000 uses in typical installations. Urine is received through the drain holes and passes through an immiscible layer of biodegradable sealant, continues through a siphon trap system, and flows out through a baffle to prevent the loss of sealant. A discharge tube in the housing directs the flow of urine into the building drain system. The cartridge is designed as a replaceable component when its function has been exhausted.

DRAIN COUPLER*

The housing is connected to the building drain system by means of the Falcon Uni-coupler. The coupler conforms to NSF 14 for plastic pipes and fittings and is designed to be used in both retrofit and new installations. It offers a variety of configurations which allow it to couple to most existing drain openings.

DRAIN CONNECTION AND MATERIAL

Installs on standard 2-inch drain connections with spud flange or threaded nipple. Suitable DWV materials include cast iron, galvanized steel, ABS, and PVC.

Waterfree urinals should not be installed on copper DWV due to copper's susceptibility to corrosion.

Information in this document is subject to change without notice.

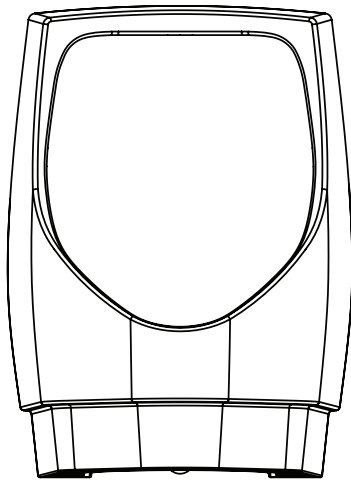

FRONT VIEW

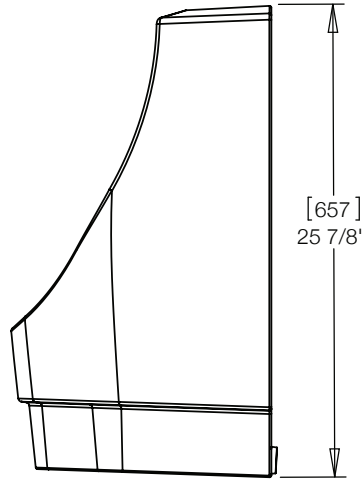

SIDE VIEW

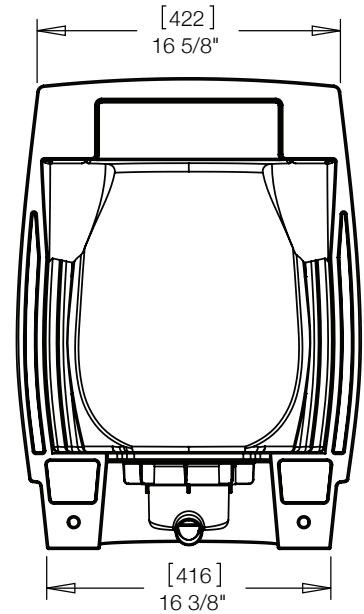

BACK VIEW

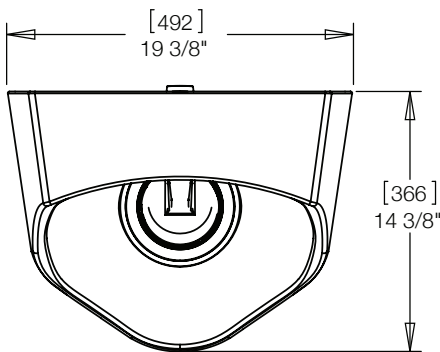

TOP VIEW

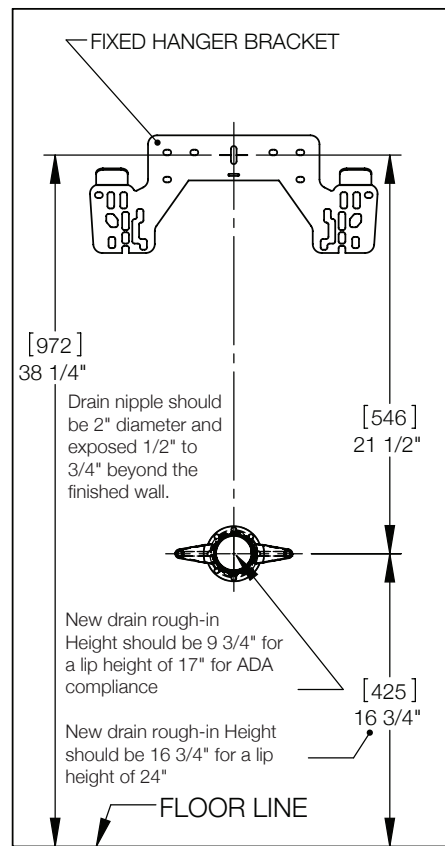
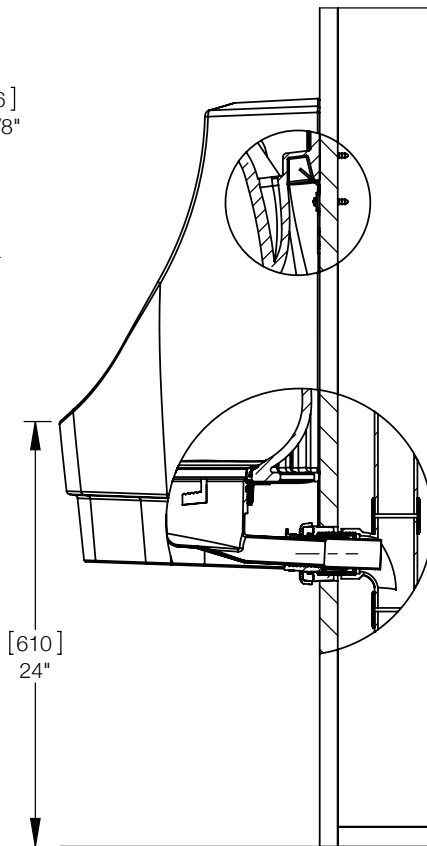
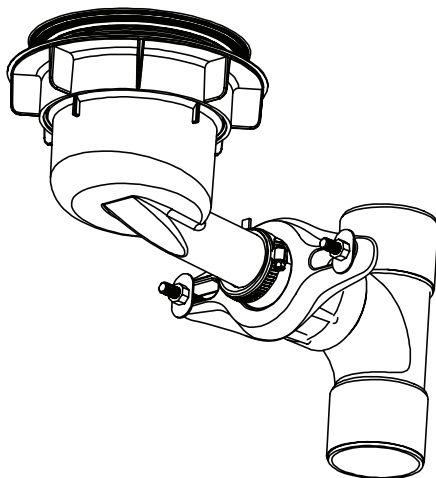

The information in this document is subject to change without notice.